

# VL-8K7C-C80F-2

High Sensitivity & High Speed Color Line Scan Camera



The VL-8K7C-C80F-2 is Vieworks' first CMOS color line scan camera which offers color images based on a dual line  $7 \mu\text{m} \times 7 \mu\text{m}$  architecture with RGB Bayer filter arrayed pixels. The VL-8K7C-C80F-2 camera delivers a maximum line rate of 80 kHz at 8k resolution. This camera features exposure control with  $100\times$  anti-blooming and is available with the Camera Link interface. Featuring high sensitivity and high speed, this camera is ideal for wide range of demanding applications such as flat panel display inspection, printed circuit board inspection, and high-performance document scanning.

# VL-8K7C-C80F-2

High Sensitivity & High Speed Color Line Scan Camera

## Main Features

- CMOS Color Line Scan
- Up to 80 kHz at 8k Resolution
- 100× Anti-blooming
- Exposure Control
- Pre-emphasis Function
- Programmable User Setting Commands

## Applications

- Flat Panel Display Inspection
- Printed Circuit Board Inspection
- High Performance Document Scanning
- Printing and Packaging System

## Specifications

Model	VL-8K7C-C80F-2	
Resolution (H × V)	8192 × 2	
Sensor (AMS)	Dragster DR-2x8k-7-RGB	
Sensor Type	Linear CMOS	
Pixel Size	7.0 μm × 7.0 μm	
Sensor Output	2 / 3 / 4 / 6 / 8 Tap	
Interface	Camera Link Base / Medium / Full, 26-pin MDR Connector	
Max. Line Rate Per a Line	2 Tap	20 kHz
	3 Tap	29 kHz
	4 Tap	40 kHz
	6 Tap	58 kHz
	8 Tap	80 kHz
Exposure time	2.00 μs ~ 10000.00 μs (0.01 μs step)	
Pixel Data Format	8 bit (2 / 3 / 4 / 6 / 8 Tap) / 10 bit (2 / 4 Tap) / 12 bit (2 / 4 Tap)	
Camera Link Pixel Clock Speed	50 / 60 / 70 / 85 MHz	
Trigger Synchronization	Free-Run, External Sync, External Sync Converter	
Dynamic Range	56 dB	
Black Level	0 ~ 2048 LSB at 12 bit	
Digital Gain	1.00× ~ 32.00×	
Max. Cable Length	10 m (@ 85 MHz, Standard Camera Link Cable)	
Lens Mount	M72 × 0.75 mm (Sensor to Camera Front: 12 mm)	
Dimension / Weight	80 mm × 80 mm × 43 mm / 390 g	
Temperature	Ambient Operating: 0 °C ~ 40 °C (Housing: 0 °C ~ 60 °C), Storage: -40 °C ~ 70 °C	
Power	External	8 ~ 28 VDC
	Dissipation	Typ. 9.0 W
Compliance	CE, FCC, KC, UKCA, UL	
Configuration Software	Configurator	

# VL-8K7C-C80F-2

High Sensitivity & High Speed Color Line Scan Camera

## Spectral Transmission

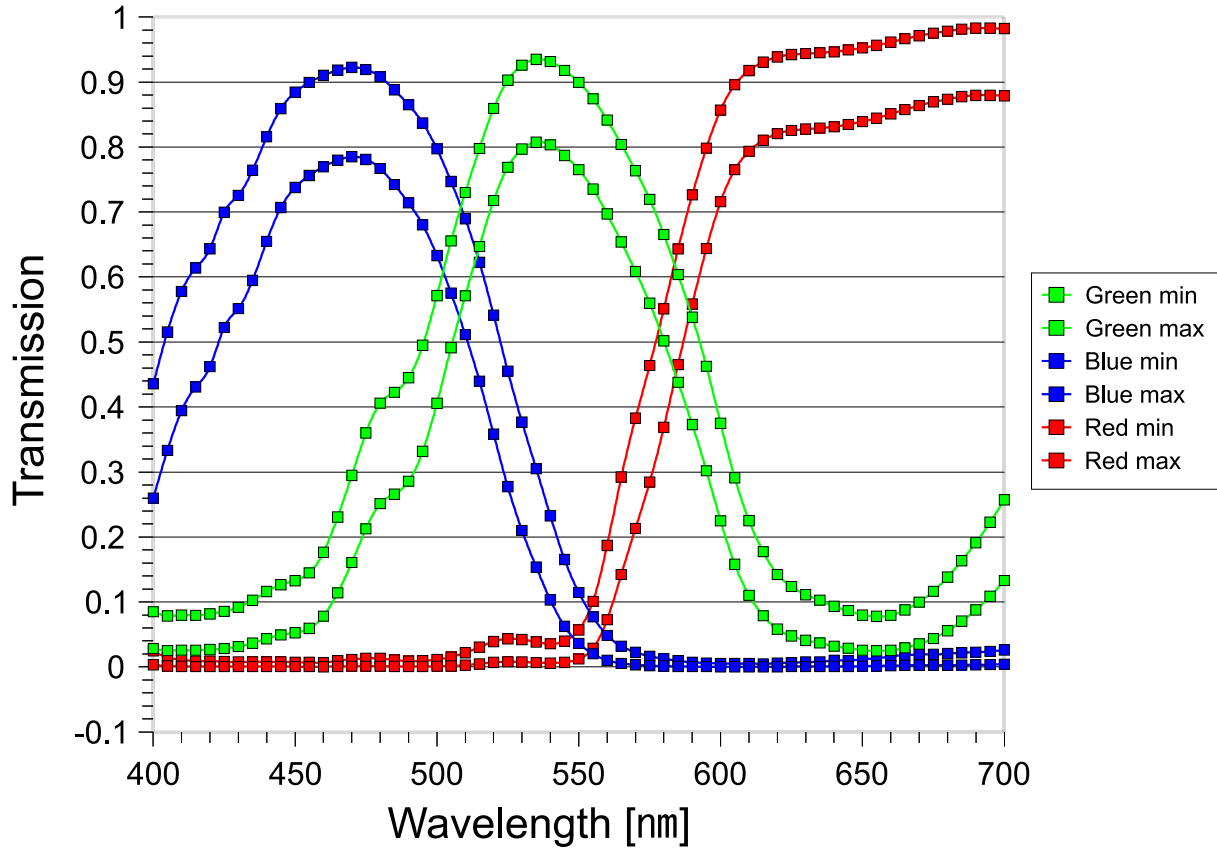

## Ordering Scheme

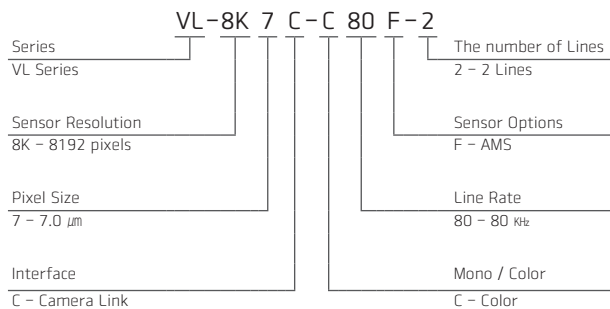

## Connector Specification

Power

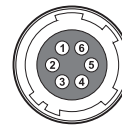

1, 2, 3: +12 VDC  
4, 5, 6: GND  
(HR10A-7R-6PB)

Control

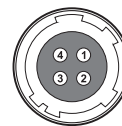

1: Trigger IN+  
2: Trigger IN-  
3: DC Ground  
4: Strobe Out+  
(HR10A-7R-4S)

Connectors on camera body

# VL-8K7C-C80F-2

High Sensitivity & High Speed Color Line Scan Camera

## Mechanical Dimensions

Unit: mm

