

VNP-200MX

200 MEGAPIXEL PIXEL SHIFTING CAMERA
EQUIPPED WITH THERMOELECTRIC PELTIER



CoaXPress®

The VNP-200MX, a pixel shifting camera equipped with thermo-electric Peltier (TEC) cooled, is designed not only for applications where extremely high resolution is required but also where high quality image is essential. The TEC maintains the operating temperature of the image sensor at up to 10 degrees below ambient temperature to reduce noise significantly. Pixel shifting technology based on a precise piezoelectric stage allows image captures as high as 427 million pixels using the VNP-200MX camera. Its CoaXPress interface supports transmitting image data at up to 25 Gbps using four coaxial cables. This camera is ideal for applications such as FPD inspection, document / film scanning, research and scientific imaging.

VNP-200MX

200 MEGAPIXEL PIXEL SHIFTING CAMERA EQUIPPED WITH THERMOELECTRIC PELTIER

Main Features

- * 50 Megapixel Resolution (AMS CMOSIS)
- * Nano Stage Pixel Shifting Mechanism
- * Extended Resolution up to 427 MP at 3 fps (9 Shot Mode)
- * Thermoelectric Peltier Cooling
- * CoaXPress Interface up to 30 fps at 25 Gbps using 4 CH
- * Pixel Defect Correction
- * Flat Field Correction
- * DSNU and PRNU Correction

Applications

- * FPD and PCB Inspection
- * Semiconductor Inspection
- * High Speed 3D Imaging
- * Digitizing and Scanning
- * Research and Scientific Imaging

Specifications

Model	VNP-200MX-M/C 30			
Resolution (H × V)	7920 × 6004			
Sensor	AMS CMOSIS CMV 50000			
Sensor Size	36.43 mm × 27.62 mm (Diagonal: 45.72 mm, Optical Format: 35 mm)			
Sensor Type	High Speed CMOS Image Sensor			
Pixel Size	4.6 μm × 4.6 μm			
Interface	CoaXPress			
Max. Frame Rate	47.5 MP	1CH: 7.7 fps @ 6.25 Gbps	2CH: 15.5 fps @ 6.25 Gbps	4CH: 30.9 fps @ 6.25 Gbps
	190 MP	1CH: 2 fps @ 6.25 Gbps	2CH: 3.9 fps @ 6.25 Gbps	4CH: 7.7 fps @ 6.25 Gbps
	427 MP	1CH: 1 fps @ 6.25 Gbps	2CH: 1.7 fps @ 6.25 Gbps	4CH: 3.4 fps @ 6.25 Gbps
Exposure Time (1 μs step)	1 μs – 60 s			
Partial Scan (Max. Speed)	3968 fps at 4 Lines			
Pixel Data Format	Mono	Mono 8 / Mono 10 / Mono 12		
	Color	BG Bayer 8 / BG Bayer 10 / BG Bayer 12		
Electronic Shutter	Global Shutter			
Exposure Mode	Free-Run, Timed and Trigger Width			
Dynamic Range	64 dB			
Gain Control	1 × ~ 30 × (1/1024 step)			
Black Level Control	0 ~ 256 LSB at 12 bit (1 LSB step)			
Shift Range	0 ~ 7.5 μm, 1 nm step			
Shift Resolution	0.001 μm			
Shift Control	Sequence Mode (mono4, mono9, mono2H, mono2V, bayer4, bayer16)			
Cooling Method	Thermoelectric Peltier Cooling			
Cooling Performance	10°C below ambient temperature / Standard cooling with a fan			
Dimension / Weight	90 mm × 90 mm × 191 mm, 1,920 g			
Temperature	Operating: -5°C ~ 40°C, Storage: -40°C ~ 70°C			
Lens Mount	F-mount, Custom mount available upon request			
Power	External	10 ~ 24 V DC, Typ. 26.0 W		
	PoCXP	Not supported		
Compliance	CE, FCC, KC			
API SDK	Vieworks Imaging Solution 7.X			

VNP-200MX

200 MEGAPIXEL PIXEL SHIFTING CAMERA EQUIPPED WITH THERMOELECTRIC PELTIER

Quantum Efficiency Curves

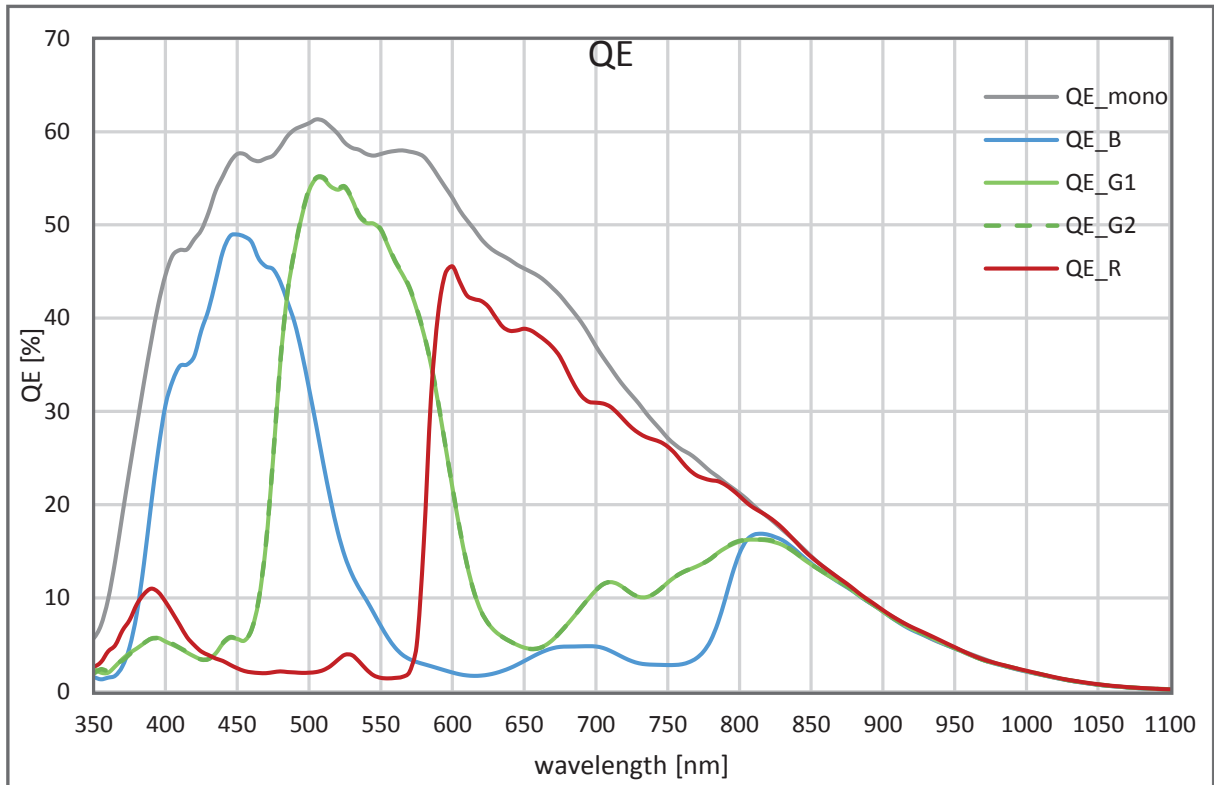

Ordering Scheme

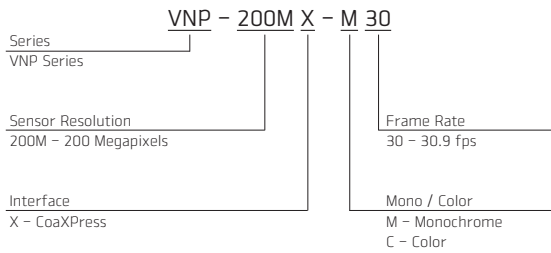

Connector Specification

Power



1 2 3: +12V DC, 4 5 6: GND
(HR10A-7R-6PB)

Control



1: Trigger IN+, 2: Trigger IN-
3: Strobe Out-(GND), 4: Strobe OUT+
(HR10A-7R-4S)

Data Transfer / Communications

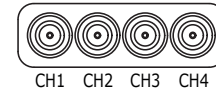

CH1: Master Connection
(75 Ω, DIN 1.0/2.3)

Connectors on camera body

VNP-200MX

200 MEGAPIXEL PIXEL SHIFTING CAMERA EQUIPPED WITH THERMOELECTRIC PELTIER

Mechanical Dimensions

Unit: mm

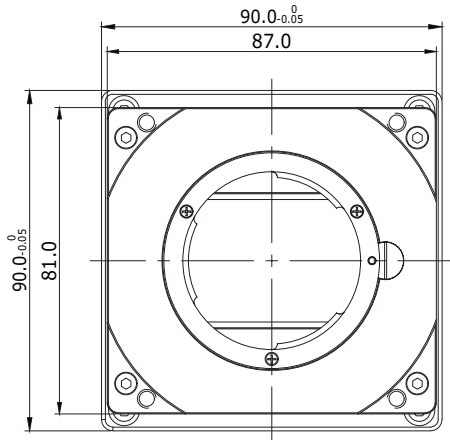

<Front View>

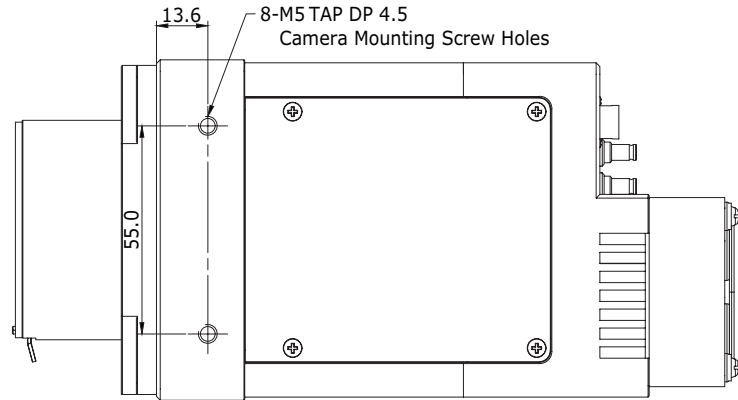

<Top View>

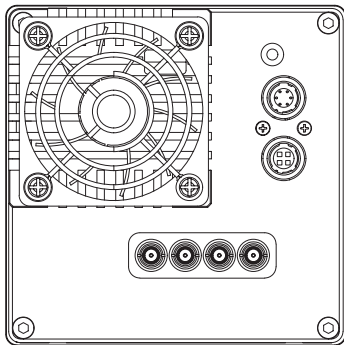

<Back View>

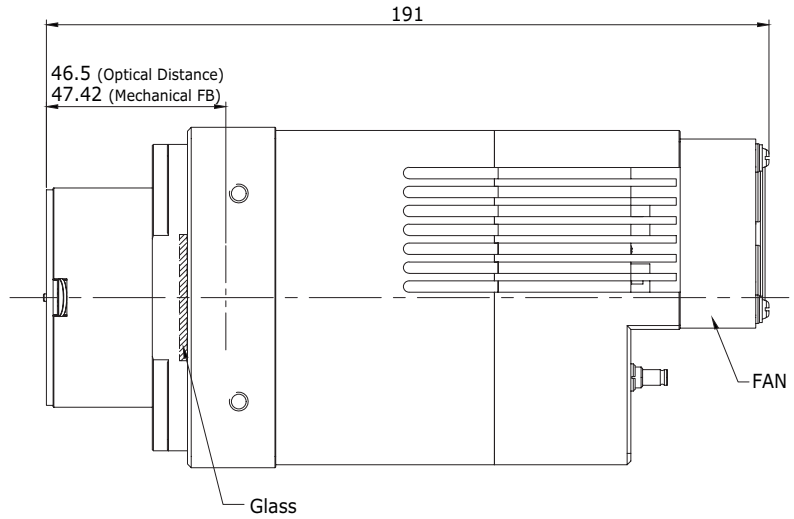

<Side View>