

VC-21MHF-M/C580I

The Fastest Speed & High Resolution CMOS Digital Camera
with CoaXPress-over-Fiber Interface



CoaXPress®
over-Fiber

The VC-21MHF-M/C580I camera is Viewsworks' first camera with the CoF(CoaXPress over Fiber) interface that offers 580 frames per second at 5120 × 4096 resolution. This new interface supports transmitting image data at up to 100 Gbps. Equipped with the Viewsworks' innovative technologies, this camera delivers not only very fast frame rates but also big availability to extend lengths for cables.

Featured with high speed and high performance, the VC-21MHF-M/C580I camera is an excellent choice for applications that require high speed and resolutions, such as FPD, PCB and semiconductor inspections.

For wide range of choice, Viewsworks provides this amazing product in two different types, the fan type and the heat sink type, with the same specification.

VC-21MHF-M/C580I

The Fastest Speed & High Resolution CMOS Digital Camera with CoF Interface



Main Features

- High Speed 21 Megapixel CMOS Image Sensor
- CoaXPRESS over Fiber Interface up to 100 Gbps using 1 Link
- Global Shutter CMOS Technology
- DSNU and PRNU Correction
- Flat Field Correction
- Defective Pixel Correction
- GenICam Compatible – XML based Control

Applications

- FPD and Electronics Inspection
- Semiconductor Inspection
- Research and Scientific Imaging
- Document / Film Scanning

Specifications

Model	VC-21MHF-M/C580I	
Resolution (H × V)	5,120 × 4,096	
Sensor	Gpixel GSPRINT 4521	
Optical Format (Diagonal)	23.04 mm × 18.43 mm (29.5 mm)	
Sensor Type	High Speed CMOS Image Sensor	
Pixel Size	4.5 μm × 4.5 μm	
Interface	CoaXPRESS over Fiber	
Optical Transceiver	100G QSFP28 SR4	
Max. Frame Rate (8 bit)	580 fps	
Exposure Time	4 μs to 10 s	
Partial Scan (Max. Speed)	18370 fps at 32 Lines	
Pixel Data Format	Mono	Mono 8/10 bit
	Color	GB Bayer 8/10 bit
Electronic Shutter	Global Shutter	
Gain Control	Analog	1.0×, 1.3×, 2.0×, and 4.2×
	Digital	1 × to 32 ×
Black Level Control	0 to 64 LSB at 10 bit	
Trigger Synchronization	Free-Run, Hardware Trigger, Software Trigger or CXP	
External Trigger	3.3 V to 24.0 V, 10 mA, Logical Level Input, Optically Isolated	
Software Trigger	Asynchronous, Programmable via Camera API	
Dynamic Range	Typ. 62.14 dB at 10 bit	
Dimension / Weight	tbd	
Temperature	Operating: 0°C to 40°C, Storage: -40°C to 70°C	
Lens Mount	F-mount, Custom mount available upon request	
Power	External	11 to 24 VDC
	Dissipation	Typ. 26 W
Compliance	CE, FCC, and KC	

VC-21MHF-M/C580I

The Fastest Speed & High Resolution CMOS Digital Camera with CoF Interface



Spectral Response

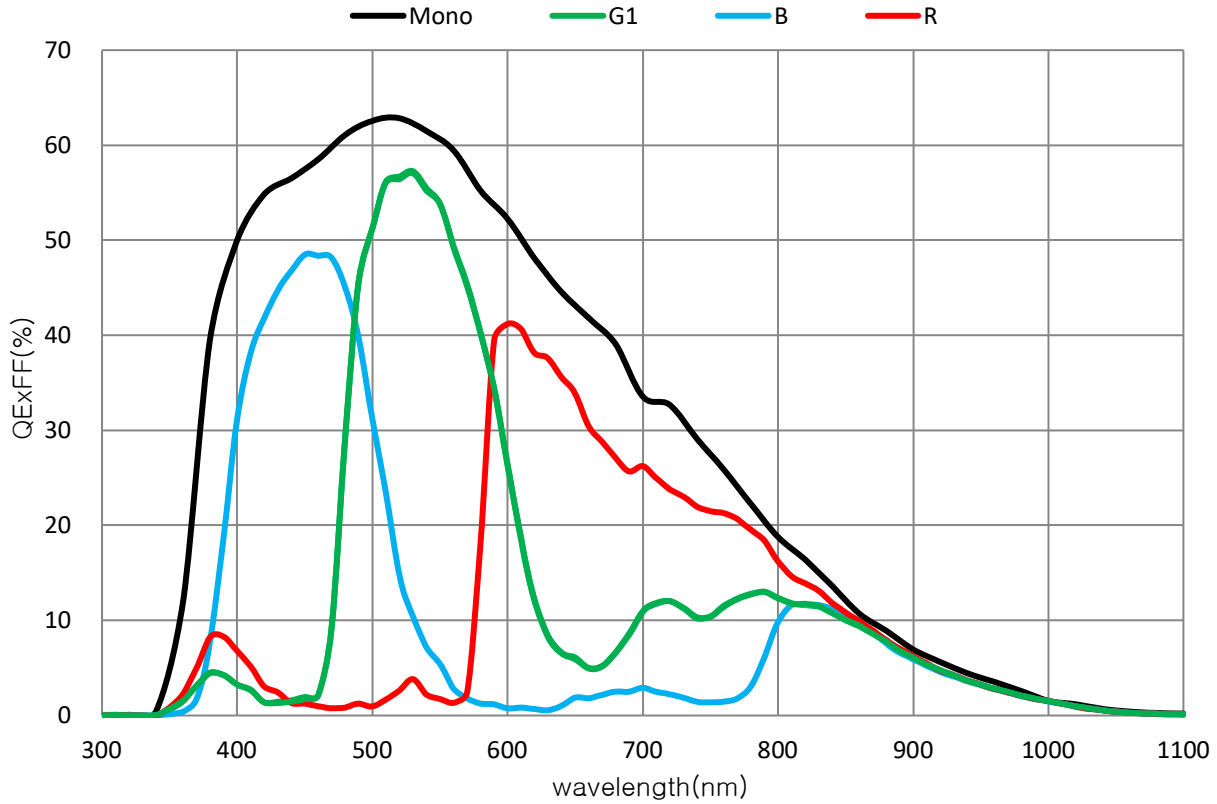

Ordering Scheme

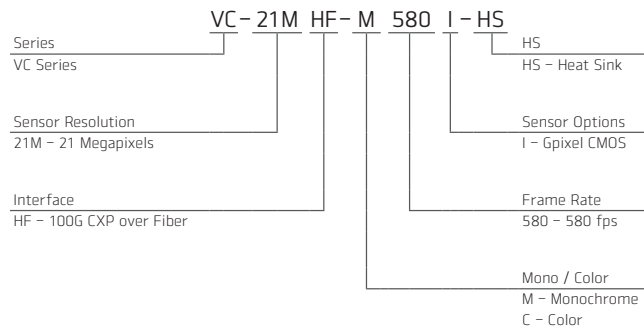

Connector Specification

Power / Control



- 1: DC Ground
- 2: +12 VDC
- 3: I/O Output-
- 4: I/O Output1+
- 5: Trigger IN-
- 6: Trigger IN+
- 7: I/O Output2+
- 8: I/O Output3+
- 9: I/O Output4+
- 10: I/O Output5+
- 11: +12 VDC
- 12: DC Ground (HR10A-10R-12PB)

Data Transfer / Communications

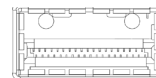

CH1: Master Connection / QSFP28

CH1

Connectors on camera body

VC-21MHF-M/C580I

The Fastest Speed & High Resolution CMOS Digital Camera with CoF Interface



Mechanical Dimensions

Unit: mm

[tbd]

Unit: mm



sales@visionsystemtech.com